

Plan Information

Tenure Type	Freehold
Plan Type	Deposited Plan
Plan Purpose	Subdivision

Plan Heading

Lots 101-110, 115-125, 134-146, 157-160, 9001, Roads and Restrictive Covenant

Locality & Local Government

Locality	Dayton
Local Government	City of Swan

Department of Planning, Lands and Heritage

File Number

Examination

Examined	Date
----------	------

Planning Approval

Planning Authority	Western Australian Planning Commission
Reference	160773, 163148

Delegated under S. 16 P&D Act 2005	Date
------------------------------------	------

In Order For Dealings

Subject To	
------------	--

For Inspector of Plans and Surveys	Date
------------------------------------	------

Plan Approved Reg. 26A (4)

Inspector of Plans and Surveys / Authorised Land Officer	Date
--	------

Survey Details

Field Records	131532, 157447
Declared as Special Survey Area	Yes

Survey Method Regulatory Statement

Survey carried out under Reg. 26A Special Survey Area Guidelines. See survey sheet(s) to determine the true final position and type of all survey marks placed for this plan.

Survey Method and Plan Content Variations

Approved Variation Type	Reference
-------------------------	-----------

Survey Certificate - Regulation 54

I, Charles A. YOUNGE hereby certify that this plan is accurate and is a correct representation of the -
 (a) survey; and
 (b) calculations from measurements recorded in the field records, undertaken for the purposes of this plan and that it complies with the relevant written law(s) in relation to which it is lodged.

FINAL	
Licensed Surveyor	Date

Survey Organisation

Name	MNG MCMULLEN NOLAN GROUP
Address	PO Box 3526, SUCCESS W.A. 6964
Phone	6436 1599
Fax	6436 1500
Email	info @ mngsurvey.com.au
Reference	104544dp-006j

Amendments

Version	Lodgement Type	Amendment Description	Authorised By	Date
---------	----------------	-----------------------	---------------	------

Former Tenure

New Lot / Land	Parent Plan Number	Parent Lot Number	Title Reference	Subject Land Description
109, 110, 122-125, 134-137	P 12868	PT LOT 26	1577-585	
101-107, 115, 116, 140-145, 157-160	P 3698	PT LOT 547	1334-143	
108, 117-121, 138, 139, 146, 9001	P 12868 P 3698	PT LOT 26 PT LOT 547	1577-585 1334-143	

Former Tenure Interests and Notifications

Subject	Purpose	Statutory Reference	Origin	Land Burdened	Benefit To	Comments
Ⓒ	MINERAL RESERVATION		DOC T42756/1964	LOTS 117-125, 134-139, 146 & 9001		SEE DOC H613448 - NOTIFICATION OF CHANGE OF GRANTEE SEE NOTE 'Z'
Ⓒ	EASEMENT	DAMPIER TO BUNBURY PIPELINE ACT 1997	DOC C363612	LOT 9001	DBNGP LAND ACCESS MINISTER	
Ⓒ	NOTIFICATION	DAMPIER TO BUNBURY PIPELINE ACT 1997	DOC H613448	LOT 9001	DBNGP LAND ACCESS MINISTER	SEE NOTE 'Z'
Ⓒ	EASEMENT	DAMPIER TO BUNBURY PIPELINE ACT 1997	DOC C379210	LOT 9001	DBNGP LAND ACCESS MINISTER	SEE DOC H613443 - NOTIFICATION OF CHANGE OF GRANTEE SEE NOTE 'Z'
Ⓒ	NOTIFICATION	DAMPIER TO BUNBURY PIPELINE ACT 1997	DOC H613443	LOT 9001	DBNGP LAND ACCESS MINISTER	SEE NOTE 'Z'

New Interests

Subject	Purpose	Statutory Reference	Origin	Land Burdened	Benefit To	Comments
	RESTRICTIVE COVENANT	SEC 136D OF THE TLA 1893	THIS PLAN & DOC	ALL LOTS EXCEPT 9001	ALL LOTS EXCEPT 9001	
Ⓔ	RESTRICTIVE COVENANT	SEC 129BA OF THE TLA 1893	DOC	LOTS 125 & 9001	ELECTRICITY NETWORKS CORPORATION	FIRE SEPARATION
Ⓕ	RESTRICTIVE COVENANT	SEC 129BA OF THE TLA 1893	DOC	LOTS 142-146	CITY OF SWAN	NO HABITABLE BUILDINGS TO BE BUILT

New Notifications and Memorials

Subject	Purpose	Statutory Reference	Origin	Land Burdened	Benefit To	Comments
Ⓝ	NOTIFICATION (Factors Affecting Use or Enjoyment of Land)	SEC 70A OF THE TLA 1893	DOC	LOTS 125 & 9001		TRANSFORMER NOISE
	NOTIFICATION (Hazards or Other Factors)	SEC 165 OF THE P & D ACT 2005	DOC	LOTS 142-146		PROXIMITY TO DBNGP
	NOTIFICATION (Hazards or Other Factors)	SEC 165 OF THE P & D ACT 2005	DOC	LOTS 110, 124, 125 & 142-146		BUSHFIRE MANAGEMENT PLAN

LIMITED IN DEPTH TO 60.96 METRES
AS TO LOT 4 ONLY

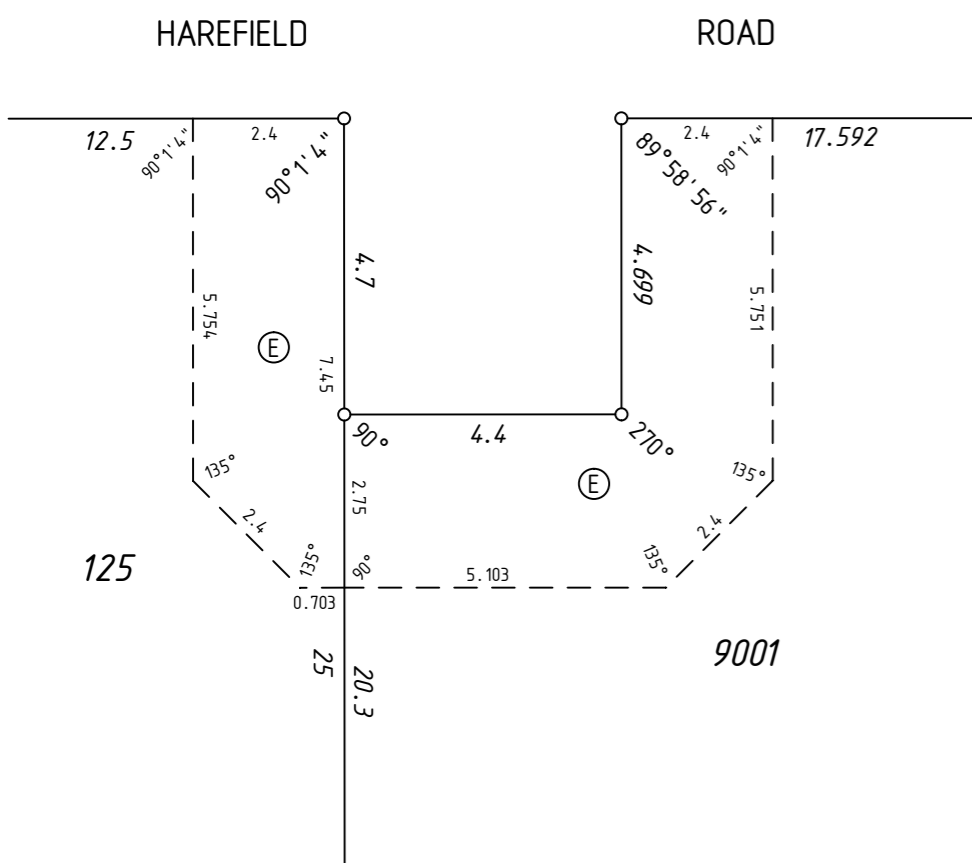

ENLARGEMENT 'B1'
Not to Scale

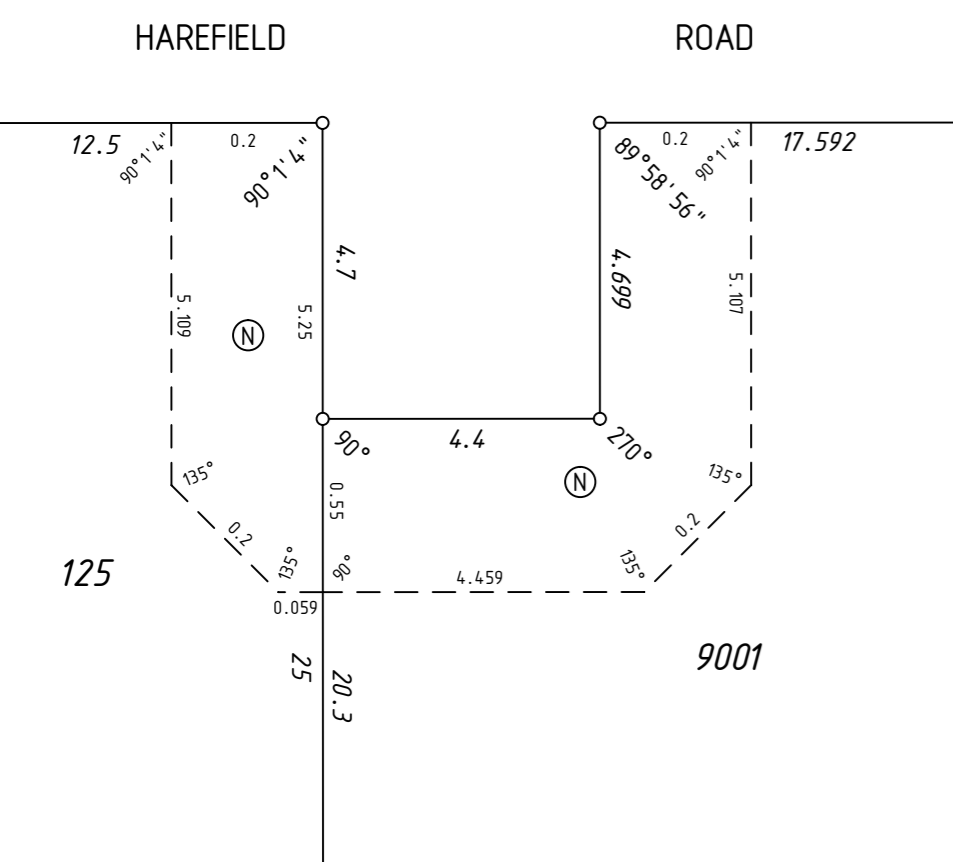

ENLARGEMENT 'B2'
Not to Scale

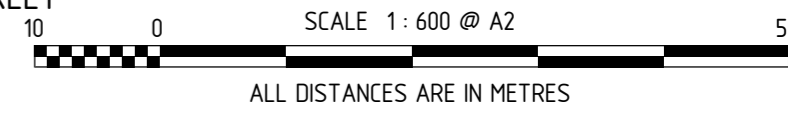
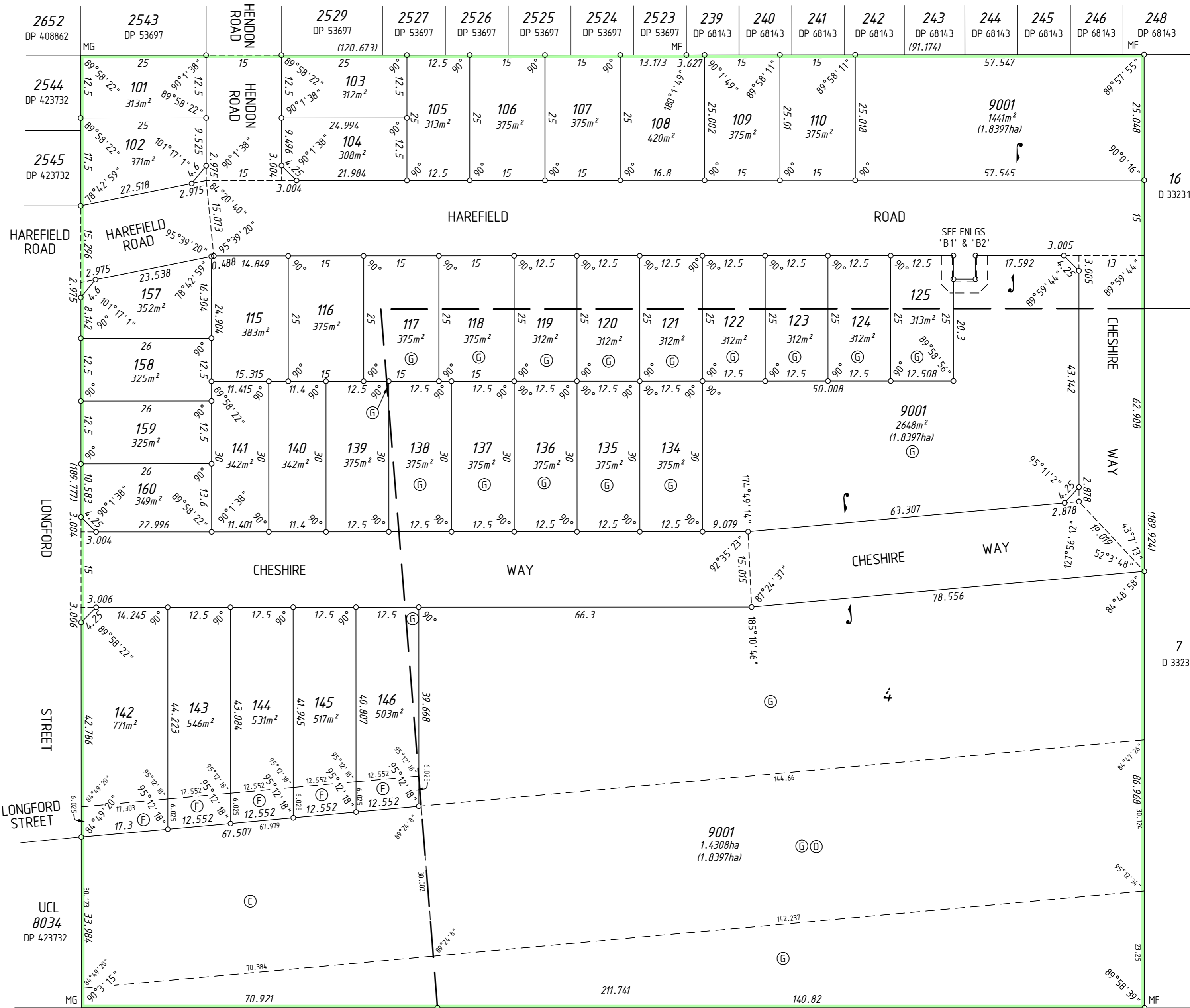

THIS SURVEY SHEET WILL BE
REPLACED BY THE SURVEY DATA



MC MULLEN NOLAN GROUP
PO Box 3326, Success W.A. 6964
Tel: (08) 6436 1500
Fax: (08) 6436 1500
Email: info@mngsurvey.com.au

MNG Ref : 104544dp-006j

VERSION NUMBER

1

DEPOSITED PLAN
423064